

# MAINTENANCE REMINDER SHEET

## L100 / L110 with 42" 3 in 1 Deck

### Lawn Tractor

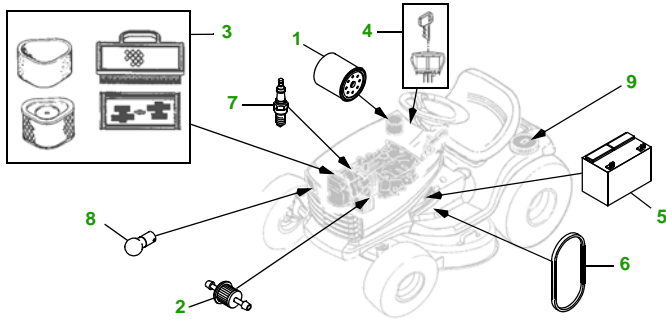

Tractor S/N

### 42" 3 in 1 Deck

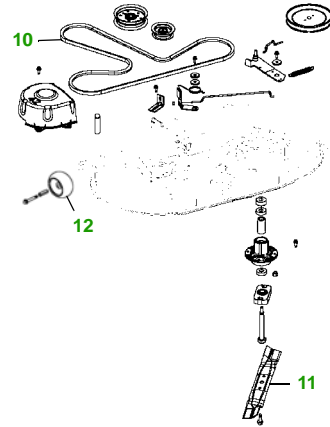

Deck S/N

Key	Part No.	Description
1	AM125424	OIL FILTER
	GY20577	OIL FILTER (PACKAGE)
2	AM107314	FUEL FILTER - IN-LINE
	GY20709	FUEL FILTER (PACKAGE)
3	M149171	FOAM AIR FILTER (L100)
	GY20573	PAPER AIR FILTER (L100) (PACKAGE)
	GY20661	AIR FILTER (L110) (PACKAGE)
4	GY20680	KEY - PADDED - (PACKAGE)
	GY20074	IGNITION SWITCH
5	TY25878	BATTERY

Key	Part No.	Description
6	GX22036	BELT - TRACTION DRIVE (L100)
	GX20006	BELT - TRACTION DRIVE (L110)
7	M78543	SPARK PLUG
8	AD2062R	HEADLIGHT BULB
9	GX22166	FUEL CAP
10	GX20072	BELT (PACKAGE)
11	GX20249	BLADE - STANDARD
	GY20567	BLADE (PACKAGE) (PACKAGED QTY - 2 BLADES)
	GX20433	BLADE - MULCH
12	GX10168	GAGE WHEEL

#### Service Recommendations

#### "As Needed" Parts

Qty	Part No	Item	Qty or Capacity	Change Interval in Hours
10	AM125424	Engine Oil Filter	1	Every 25 Hours
20	TY22029 or TY22076	1 Qt. Engine Oil Turf Gard @ 10W30 2 1/2 Gal. Engine Oil Turf Gard @ 10W30	1.5 qt (L100) 2.0 qt (L110)	Every 25 Hours
10	AM107314	Fuel Filter	1	Every 25 Hours
10	M78453	Spark Plug	1	Every 25 Hours
2	GY20305	Belt - Mower deck L100 & L110	1	100/200

Qty	Part No	Item
1	M149171	Air Filter Element Foam - L100
1	GY20573	Air Filter Element Paper - L100
1	GY20661	Air Filter - L110
2	GX20249	Blade -Standard
2	GX20433	Blade -Mulch
1	GX22036	Belt - Traction Drive (L100)
1	GX20006	Belt - Traction Drive (L110)
1	GX20072	Belt - Mower
1	GY20680	Key Padded
1	GX22166	Fuel Cap
1	TY15272	Mower Deck Leveling Gauge
1	TY15410	Grease Gun

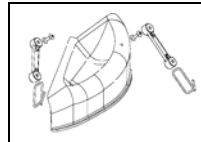

Mulch Cover Kit ..... GY00115 (Package)

Dealer Name  
Contact Name  
Dealer Phone No



#### Home Maintenance Kit

Unit	Kit Number
L100	LG251
L110	LG240

